

THIS DRAWING IS UNPUBLISHED. RELEASED FOR PUBLICATION, 19 .  
 © COPYRIGHT 19 BY AMP INCORPORATED. ALL INTERNATIONAL RIGHTS RESERVED.

LOC		DIST		P		F		ZONE		LTR		REVISIONS		DATE	APPD
AF	50									A		REVISED PER 063A-0451-00	24JUL00	MF-KR	

- 1 CONTINUOUS STRIP ON REELS WITH TERMINALS LOCATED ON 5.59±0.08 [.220±.003] CENTERS.
- 2 SLOT ACCEPTS 0.36-0.57mm [#27-#23] AWG COPPER MAGNET WIRE. A SINGLE WIRE ONLY.
- 3 POKE-IN ACCEPTS A 0.50-0.90mm<sup>2</sup> [#20-#18] AWG SOLID OR FUSED STRANDED LEAD WIRE.

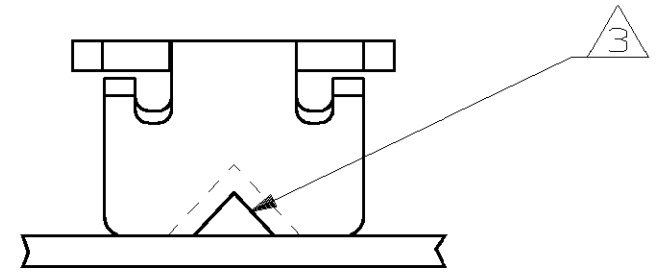

IDENTIFICATION NUMBER 10 FOR MAGNET WIRE RANGE

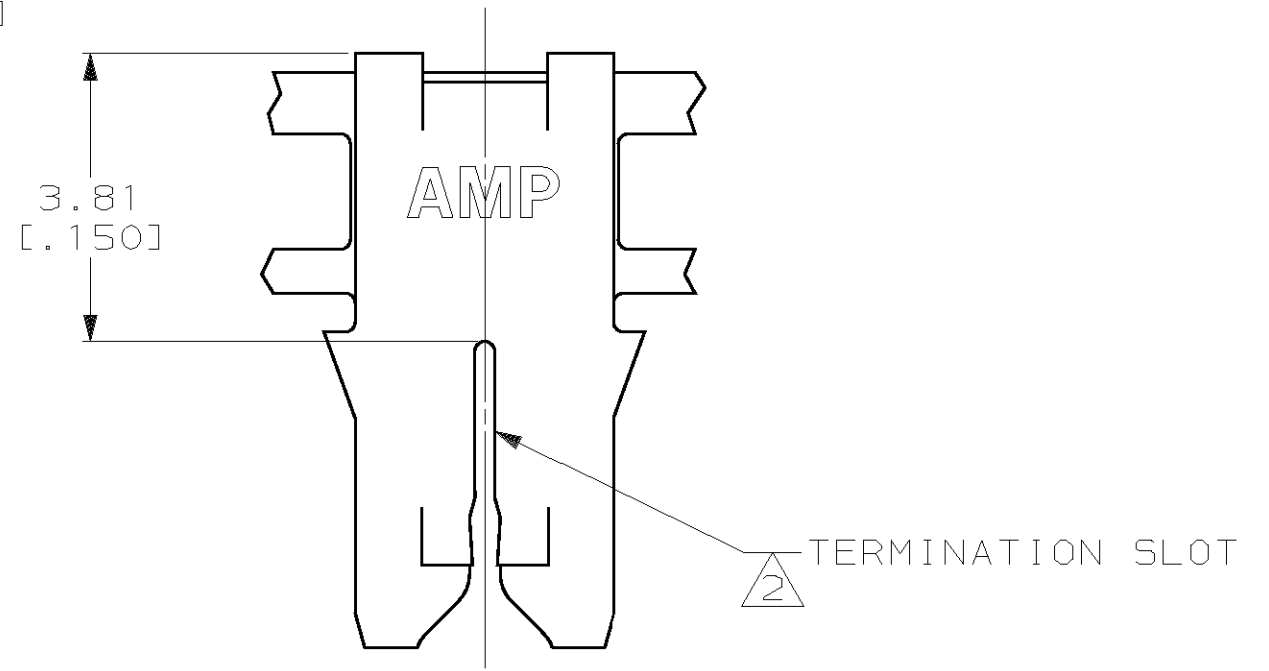
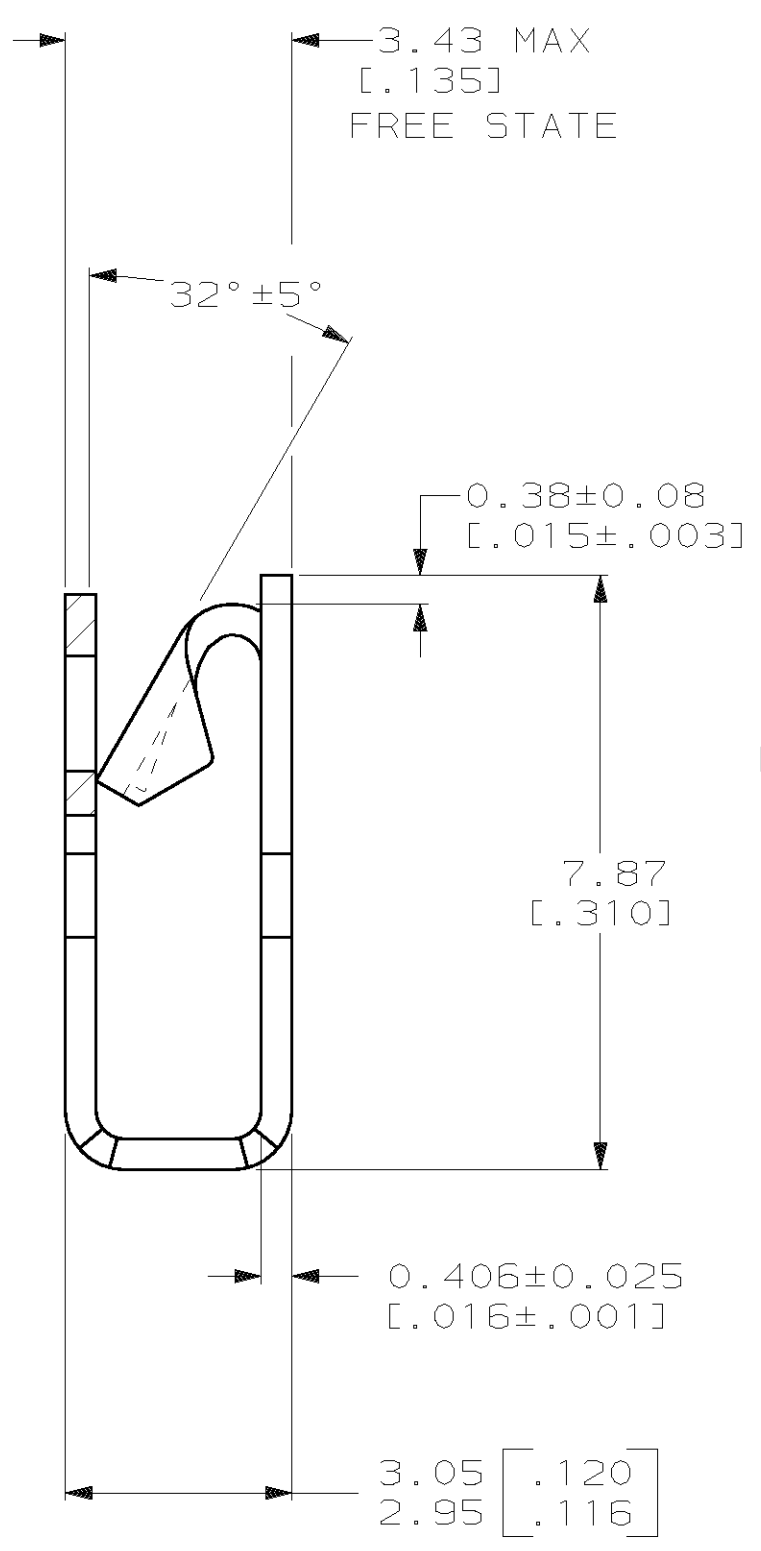
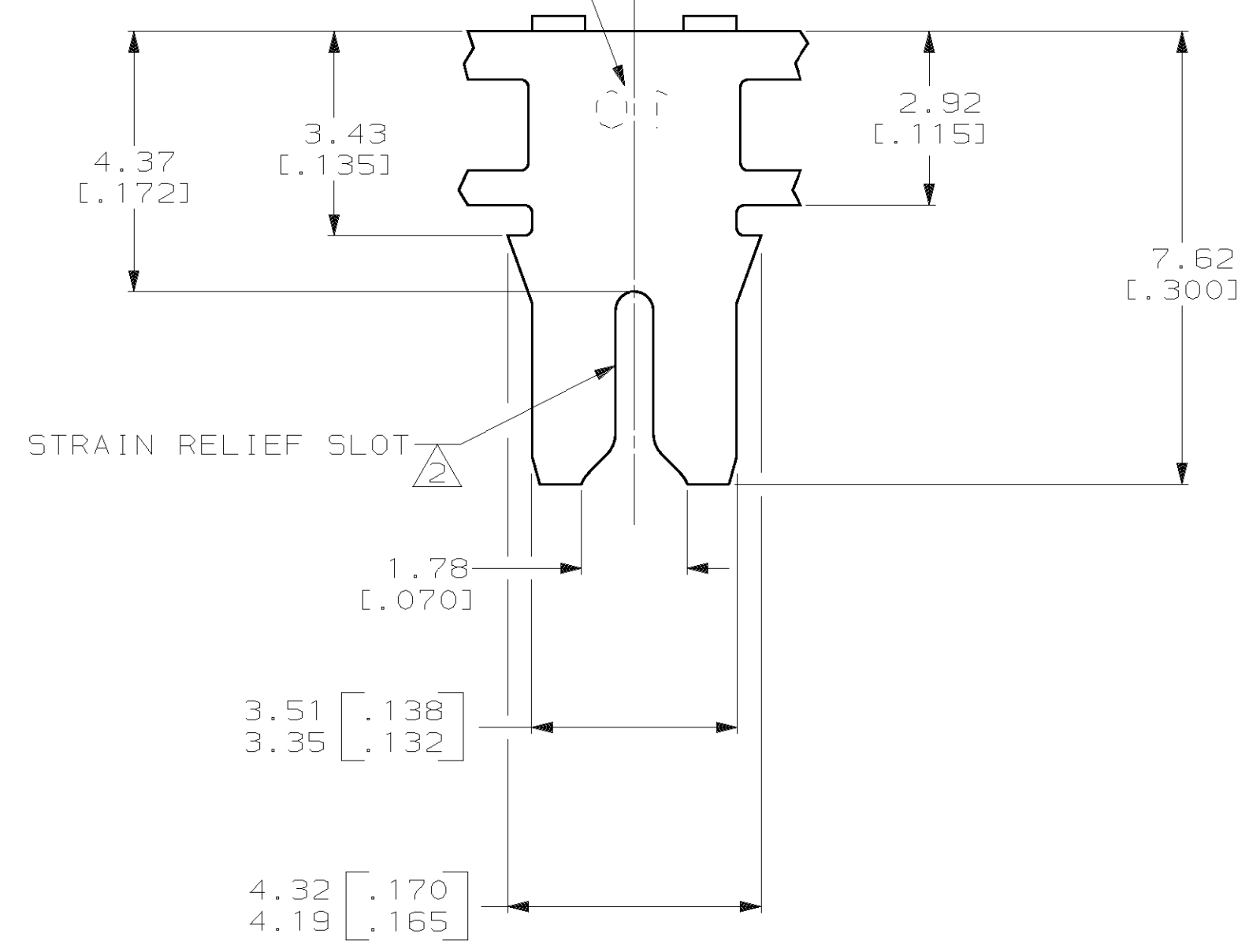

63789-1  
PART NO

DO NOT SCALE PRINT. UNLESS SPECIFIED DIMENSIONS IN mm [INCHES] TOLERANCES ON: 2 PLC DEC ± 0.25 [.010] 3 PLC DEC ± - ANGLES ± -	DR 2/JUN/94 RAYMOND R. BUCHHEISTER JR.	AMP Incorporated Harrisburg, PA 17105-3608	
	CHK 2/JUN/94 MICHAEL S. FEHER		
MATERIAL 4M BRASS	APPD 2/JUN/94 TERRY L. SHUTTER	TERMINAL, POKE-IN, 300 SERIES MAG-MATE™	
FINISH 0.002032 [.000080] MIN TIN PLATE	PRODUCT SPEC 108-2012	SIZE C 00779	DRAWING NO C=63789
	APPLICATION SPEC 114-2046	SCALE 10:1	SHEET 1 OF 1
	WEIGHT -		

THIS DRAWING IS A CONTROLLED DOCUMENT FOR AMP INCORPORATED. IT IS SUBJECT TO CHANGE AND THE CONTROLLING ENGINEERING ORGANIZATION SHOULD BE CONTACTED FOR THE LATEST REVISION.